

# LEGACY<sup>®</sup> *SERIES II*



High Performance Power Amplifier

**MODEL : LA 220**

Owner's Manual for Legacy Car Amplifiers



# INTRODUCTION

Thank you for purchasing the LEGACY LA220 SERIES II Amplifier. The LA220 was engineered in the USA to the highest quality level and will provide you with years of high quality sound level amplification and reproduction.

The LA220 utilizes 2 MOSFETS in its design to produce enough voltage to supply the main amplifier and a huge considerable amount of reserve voltage for peak "high demand" situations.

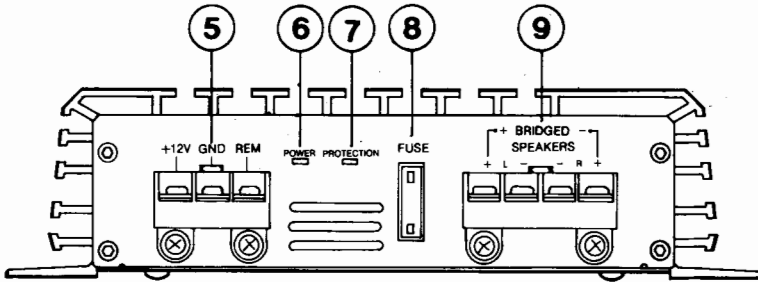
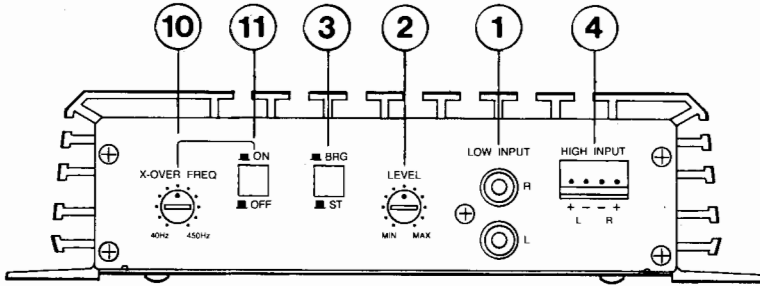

- |   |                           |   |                             |
|---|---------------------------|---|-----------------------------|
| ① | Input RCA Jack            | ⑦ | Protection LED              |
| ② | Input Level Control       | ⑧ | Fuse Holder                 |
| ③ | Bridged Mode Switch       | ⑨ | Speaker Output Terminal     |
| ④ | High Level Input          | ⑩ | Crossover Frequency Control |
| ⑤ | Power Connection Terminal | ⑪ | Crossover On/Off Switch     |
| ⑥ | Power On LED              |   |                             |

## FEATURES

---

### 1. Power On LED.

When the LA220 is properly grounded and has proper power and is receiving its remote power signal the red LED will light up indicating power conditions are correct.

### 2. Bridging Capability.

The LA220 can be bridged to a high power one channel unit. Make sure that you have a speaker or series of speakers on the bridged channel capable of handling at least 100 Watts or RMS power.

### 3. Input Gain Control.

These are NOT Your amplifiers volume controls. They are a sophisticated device which is to be utilized when matching the input signal of your head unit or equalizer to their amplifier.

Some people automatically set the gain to maximum because they want their music loud, by doing this they are also increasing the chance of burning out their amplifiers input stage should the source signal already be of a high value. Please follow the precise instructions found later in this manual to help match the signals correctly.

Your system can also become extremely sensitive to noise conditions when you have a high signal level coming into the amplifier and you also have a high gain set on the amplifier. So avoid lots of problems and match your system correctly!

### 4. Speaker Terminals.

The speaker terminals are 14K Gold Plated for high conductivity and minimum impedance loss. The terminals are facing upwards for easy wiring in tight situations. Be sure to strip just enough insulation off your speaker wires that will fit under the screw plate to help ensure against speaker wire short circuits.

The LA220 can support an impedance load as low as 2 ohms per channel or 4 ohms in the bridged mode, though a 4 ohm stereo load and 8 ohm bridge load will greatly increase the life expectancy of the amplifier.

### 5. Crossover Frequency Circuit

Lets you adjust the crossover frequency from 40-450 Hz for both channels.

### 6. Crossover On/Off Switch

Lets you set the amplifier to drive a connected subwoofer.

---

### **7. Mute Turn On Circuit.**

The LA 220 features an anti-thump delay circuit. This circuit eliminates irritating thump noises some times experienced with cheaper amplifiers when they are turned on.

### **8. Short Circuit Protection.**

Advanced protection circuits have been designed into all LEGACY amplifiers. The protection circuitry will disable the amplifier if it senses an input overload, speaker short circuit or extreme high temperature conditions. When the protection circuit is in operation the LED indicator on the unit will light indicating that the amplifier has gone into a self preservation mode. At this time please check your system to see what is causing the protection circuit to fire. The amplifier can be reset by turning the remote power off and then on again. If the system shuts down because of a thermal overload condition, allow the amplifier to cool down before restarting. If the amplifier shutdown because of an input overload or speaker short circuit please be sure to correct these conditions before restarting the amplifier.

### **WARNING!**

Do not play your music at a level which will inhibit your hearing necessary traffic safety sounds! Long term listening at extreme high levels may cause loss of hearing.

## INSTALLATION

---

The LA 220 comes complete with all mounting hardware. While the LA 220 can be mounted in any convenient location in your vehicle, please remember that this is a high power unit which generates high electrical energy and heat. Therefore be sure to install the unit in a place with sufficient airflow, a minimum of dust and no moisture. Allow enough space around the cooling fins to permit reasonable airflow and cooling.

Choose a suitable location to mount the amplifier so that it is protected from vibration.

Check clearance all around the amplifier be sure to leave enough room for wiring.

Secure the amplifier tightly. Do not leave an unmounted amplifier in your car trunk or deck as it can be a driving hazard should you be forced to make a short stop.

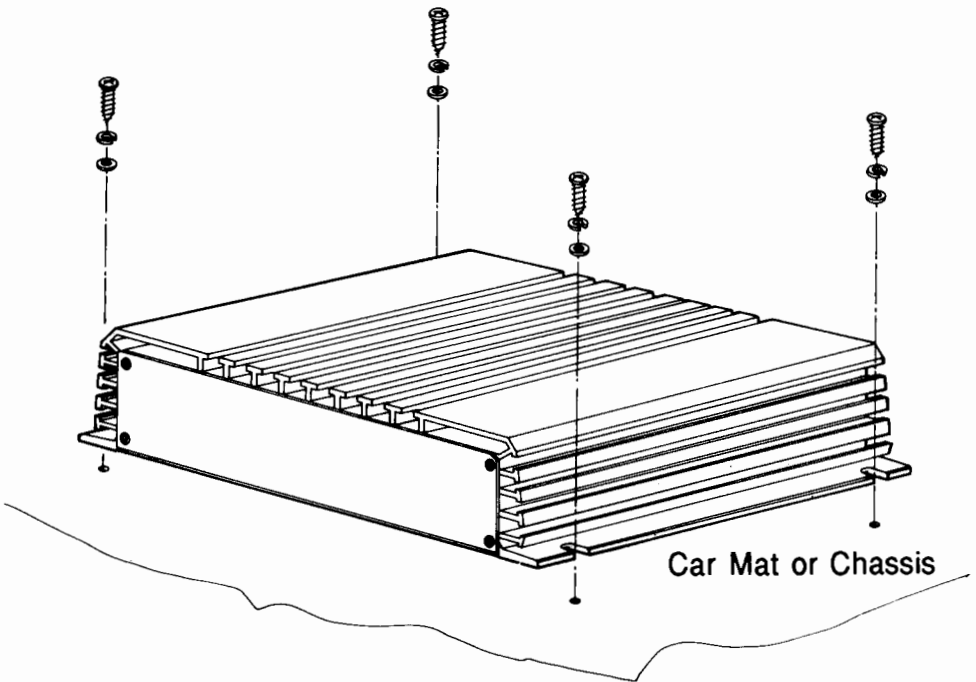

# ELECTRICAL CONNECTION

## A. STEREO INPUT CONNECTION

### RCA TYPE TERMINAL

This amplifier is provided with gold plated RCA terminals for LOW LEVEL INPUT to match radios and equalizers with line level output. Couple the RCA input with the car stereo/equalizer output using RCA type connector cables. (Fig. 1)

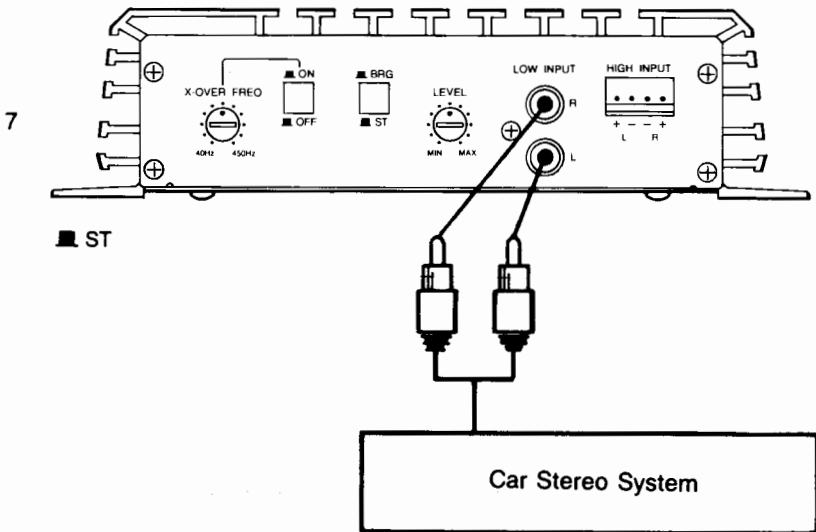

(Fig. 1)

You may want to operate two LA220 in the mono mode, in this case you will have to bridge your input signal for each amplifier to MONO\* using this format your two LA220's in MONO will provide full stereo when used simultaneously.

\* BESIDES BRIDGEING YOUR OUTPUT

## B. MONO INPUT CONNECTION

LA220 may easily be bridged for mono operation by feeding the same signal to both LEFT and RIGHT Input terminals. The simplest way is by using a Y-adaptor to connect your car stereo output to the LA220 input. No matter what output the car stereo has (some car stereos have LR, RR, LF, RF output, and some are only RIGHT and LEFT output), choose anyone of them and connect it. (Fig. 2)

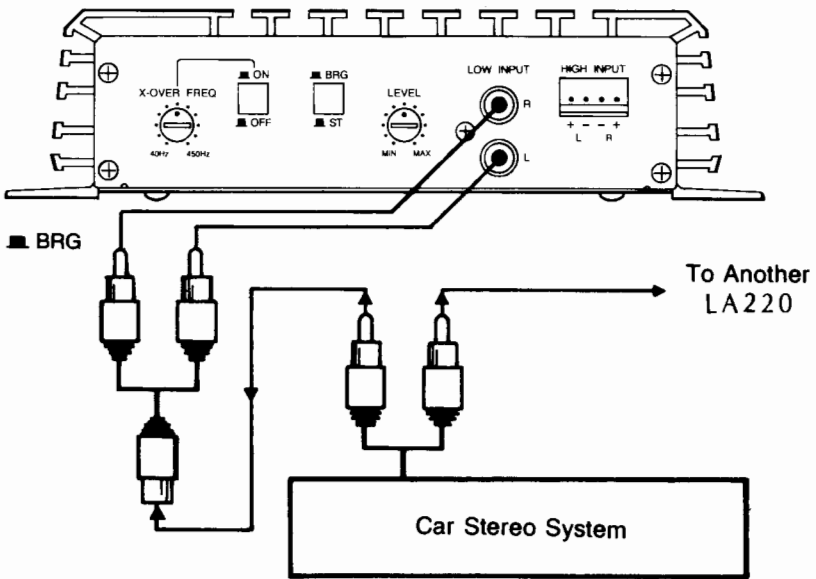

(Fig. 2)



## C. SPEAKER CONNECTION

### 1. Stereo Amp System

Connect the two pair of output terminals to corresponding LEFT and RIGHT Speakers. (Fig. 4)

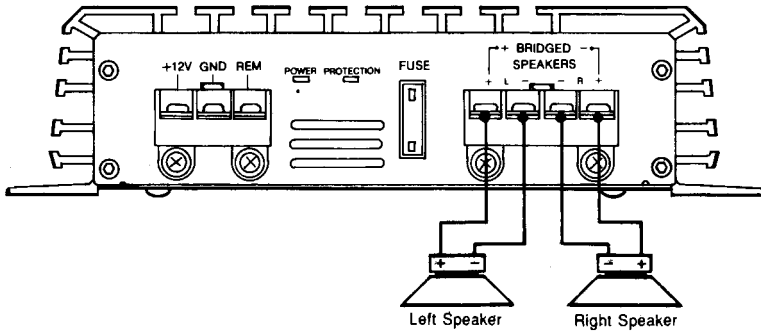

(Fig. 4)

### 2. Mono Amp System

The LEGACY LA220 amplifier is bridgeable from a 2 channel amplifier to a one channel amplifier. The ideal speaker impedance for optimum operation is 4 ohms. The amplifier will provide stable operation when operated between 2 and 8 ohms loads. The minimum recommended speaker load is 2 ohms for each channel in normal operation.

When operating in the bridged mode the minimum recommended speaker load is 4 ohms for each bridged channel. Operation of the amplifier below this impedance load can damage both the amplifier and your speaker and will void your warranty.

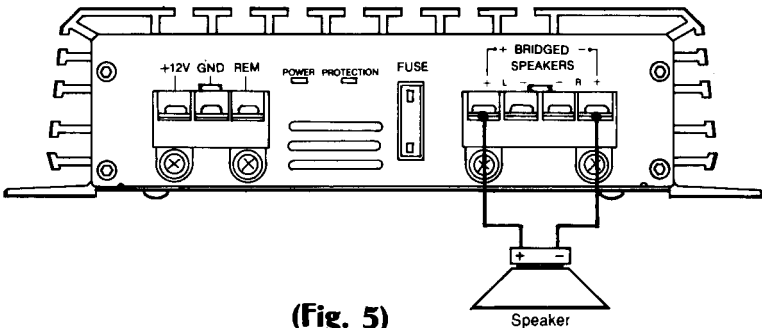

(Fig. 5)

SPEAKER NEGATIVE TERMINALS ON AMPLIFIER ARE NOT USED IN BRIDGED MODE. BRIDGING IS DONE BY SUMMING POSITIVES. CONNECT THE NEGATIVE SPEAKER TERMINAL TO THE POSITIVE TERMINAL OF R-CH ON THE AMPLIFIER BE SURE TO SELECT BRIDGED SWITCH KNOB FOR PROPER OPERATION. (Fig. 5)

#### D. POWER CONNECTION

1. Connect the B+12V pole of power supply directly to the battery (+) position terminal.
2. Connect the GND pole of power supply directly to the (-) negative ground battery terminal or car chassis.
3. To make a good grounding and prevent motor boating noise problem connect another 12 gauge minimum wire from the (-) negative battery terminal to chassis of stereo unit.
4. Connect the 'Remote' pole to external switch for positive 12V ON/OFF. This may be connected to the receiver power antenna lead.

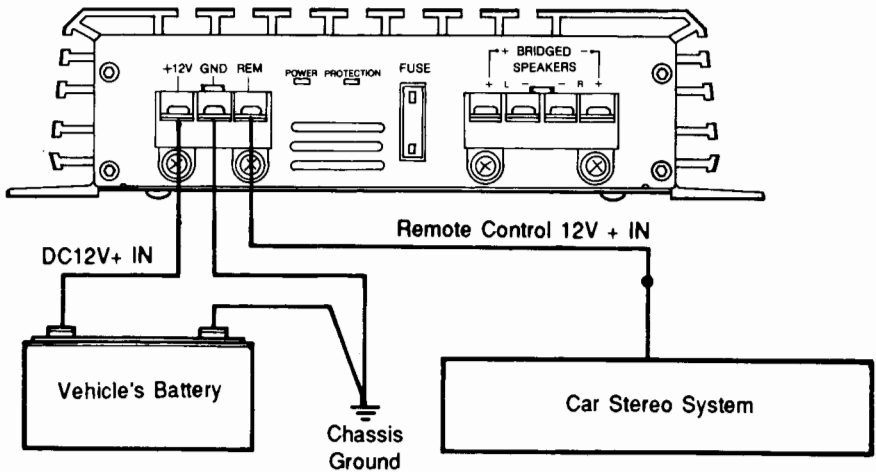

Fig. 6

# TESTING AND SPECIFICATIONS

---

1. After all the connections have been made, turn on your stereo and listen for the amplifier to turn on. If there are any unusual noises from the speakers then turn the system off and recheck all the wiring.
  
2. After you have connected your radio or equalizer to the amplifier, you may adjust the gain control to match the output level of your radio.
  - (A) Set the volume control on your radio to 2/3 position.
  - (B) Adjust the gain control for an average listening level.
  - (C) Turn the radio volume all the way down and listen for background noise.
  - (D) Start your vehicle and listen for electrical noise.
  - (E) Making fine adjustments to the sensitivity can reduce background noise and some engine noise.
  - (F) CAUTION: Never turn the sensitivity up any farther than you need to get clear sound at 2/3 volume.
  - (G) This adjustment only needs to be made once.
  
3. NOTE: CARE MUST BE TAKEN AGAINST BATTERY OVER-DISCHARGE CAUSED BY LONG OPERATION OF THE SET AT A HIGH SOUND LEVEL WHEN THE ENGINE IS NOT RUNNING OR IDLING.

## SPECIFICATIONS

1. Output Power  
@ 14.4V DC 1 KHz..... 150W × 2 MAX, 75W × 2 RMS
2. Bridged Mode..... 300W MAX, 150W RMS
3. Frequency Response..... 10-30,000 Hz ± 3dB
4. Input Impedance..... 10K ohms
5. Input Sensitivity..... 250mV-1V
6. Power Supply Voltage..... DC 14.4V negative ground (10.5-16V)
7. Matching Speaker Impedance..... 4-8 ohms
8. Maximum Current Draw..... 15A
9. Dimensions..... 200 × 50 × 252mm (W.H.D)
10. Net Weight..... 1.8 kg

